



**CROWN**®  
*Jewel* OF COOKING



Item No. \_\_\_\_\_

# L813

## Gas Lower Cook Surface/ Electric Upper Platens Two-Sided Grill

L813

### Features

One touch menu selection automatically provides accurate TIME, TEMPERATURE, and GAP settings for every product.

### Programmable Controls

Microprocessor controls are programmable for simplified operator operation. Offers flexibility for future menu items and product specification changes at the restaurant level.

### External USB Port

External USB port allows user access to upload new menu and promotional items. Menu changes can be sent electronically to other store locations, saving time and eliminating operator error.

### Upper Platens

Two upper platens will close automatically to the preset gap setting with the touch of one button. Air cylinder system provides quiet, simple, trouble-free operation of the upper platen. As a safety feature, platen will automatically open at loss of power, or if an obstruction is detected.

### Precise Automatic Gapping

Solid platform with 3-point reference plane and fixed (home) reference point. Once programmed, the upper platen automatically achieves accurate and consistent gaps, every time. Precise, repeatable gapping assures product safety and better quality finished product.

### Cooking Zones

Three separately controlled cooking zones. Three independent controlled gas infra-red burners heat the lower cook surface. Each upper platen contains two independently controlled electric heating elements. Together these thermal systems provide even plate temperatures and quick recovery.

### Side-To-Side Release Material

Protects entire upper platen cooking surface and makes cleaning easy. Improved installation and removal process away from hot surfaces.

### Patty Cook Position Placement Guide

Lower cooking surface is etched for a permanent patty placement guide for two-sided cooking.



Rockton, Illinois 61072  
**800-255-0626**  
Phone 815-624-8333 Fax 815-624-8000  
**www.taylor-company.com**  
e-mail: info@taylor-company.com

International Office  
Taylor Company S.r.l.  
Roma, Italy  
Tel: **+39-06-420-12002** Fax: +39-06-420-12034  
e-mail: romeoff@taylor-company.com

ISO 9001:2008  
Registered Firm

# L813 Gas/Electric Two-Sided Grill

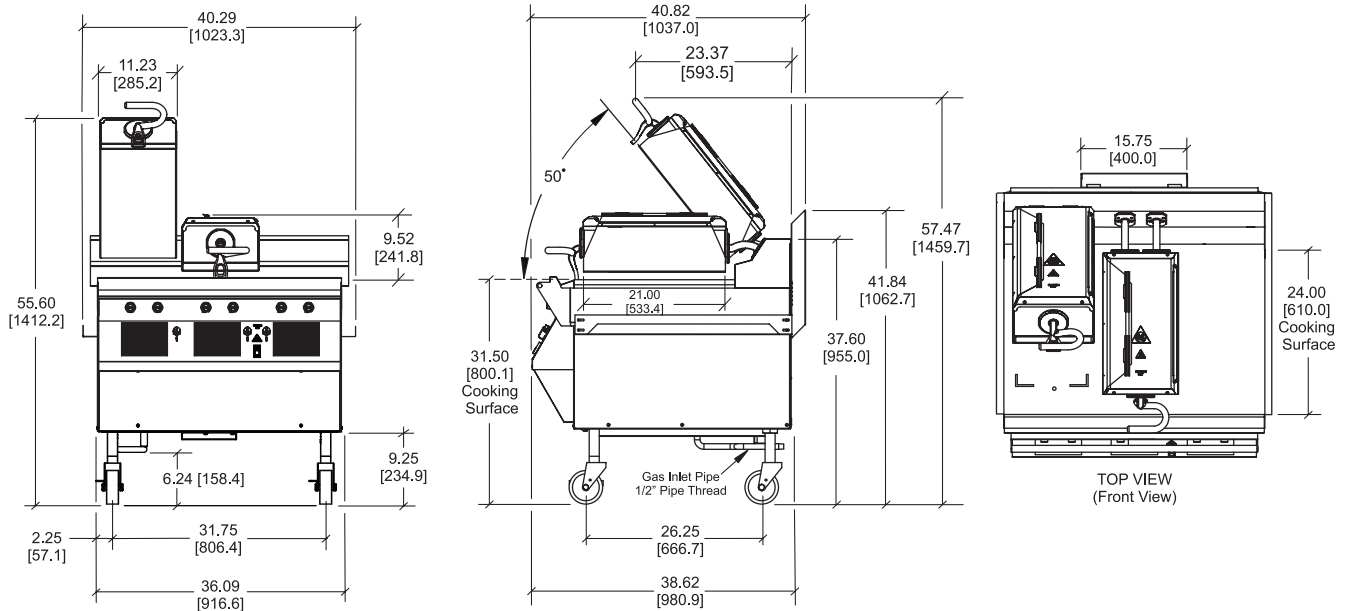

FIGURES IN BRACKETS INDICATE MILLIMETERS / DECIMAL AND FRACTIONAL DIMENSIONS EQUAL TO ( PLUS OR MINUS 1/16 INCH [1.5mm] ). MACHINE HEIGHT CAN VARY ( PLUS OR MINUS 2-1/2 INCHES [63.5 MM] ) WITH CASTER HEIGHT ADJUSTMENT / SIDE GREASE CANS NOT SHOWN.

Weights	lbs.	kgs.
Net	895	406.0
Crated	1015	460.4
	cu. ft.	cu. m.
Volume	53.7	1.52

Dimensions	in.	mm.
Width	40-5/16	1024
Depth	40-13/16	1037
Height	55 to 60	1397 to 1524
Cooking Surface Height	29 to 34	737 to 864
Floor Clearance	3-3/4 to 8-3/4	95 to 222

Casters may be adjusted.

Electrical	Total Amps	Cord Supplied with NEMA Plug
208/60/3	23	L15-30P
240/60/3	21	L15-30P
400/50/3N~	11	**

This unit may be manufactured in other electrical characteristics. Refer to the local Taylor Distributor for availability. (For exact electrical information, always refer to the data label of the unit.)

\*\* Plug supplied by customer

### Bidding Specs

Electrical: Volt \_\_\_\_\_ Hz \_\_\_\_\_ ph \_\_\_\_\_  
 Neutral: Yes No **Cooling:** Air Water NA

Options: \_\_\_\_\_

## Specifications

### Electrical

One dedicated electrical connection is required. See the Electrical chart for the proper electrical requirements. Consult your local Taylor distributor for receptacle specifications as local codes allow.

### Gas

Three ceramic infrared burners; 25,000 BTUH each.  
 Manifold pressure; 3.5" w.c. natural; 10.5" w.c. propane

Includes:

- Flue deflector and restraining cable
- 3/4" Flexible gas inlet hose, with female fitting connection for 1/2" pipe thread on grill and female fitting for 1" pipe thread at wall

## Accessories

- Cleaner (1qt)
- Grease cans (two, mount on each side)
- Release sheets; includes clips and retainer (one box of 9)
- Squeegee (one)

## Options

- Cleaning Pads (10 qty.)
- Cleaning Pad Holder
- Gap Gage (0.255)
- Grill Scraper
- Tool Holder

**Continuing research results in steady improvements; therefore, these specifications are subject to change without notice.**



**Taylor Company,**  
 Rockton, Illinois 61072  
 815-624-8333 **800-255-0626** Fax 815-624-8000  
[www.taylor-company.com](http://www.taylor-company.com)